

PART.NO.:
SP63-AP401-**-**

- 08: 功能区镀金1U", 锡脚Gold Flash
- 09: 功能区镀金3U", 锡脚Gold Flash
- 10: 功能区镀金5U", 锡脚Gold Flash
- 11: 功能区镀金15U", 锡脚Gold Flash
- 12: 功能区镀金30U", 锡脚Gold Flash

GENERAL TOLERANCE		DWG.NO.	SP63-AP401-00	PART.NO.	SP63-AP401-**-**	DRAWN	L. M. J 2015. 04. 15	UNIT	mm	SCALE	NO SCALE
x. ±0.50	x.*± 5°	REV.	A	TITLE	Micro SIM Push H1.34	CHECKED		 东莞市欧联电子科技有限公司 DONGGUAN OLN ELECTRONICS TECHNOLOGY CO., LTD.			
.x±0.25	.x*± 2°	SIZE		SHEET	1 OF 3	APPROVED					
.xx±0.15	.xx± 1°	A4									

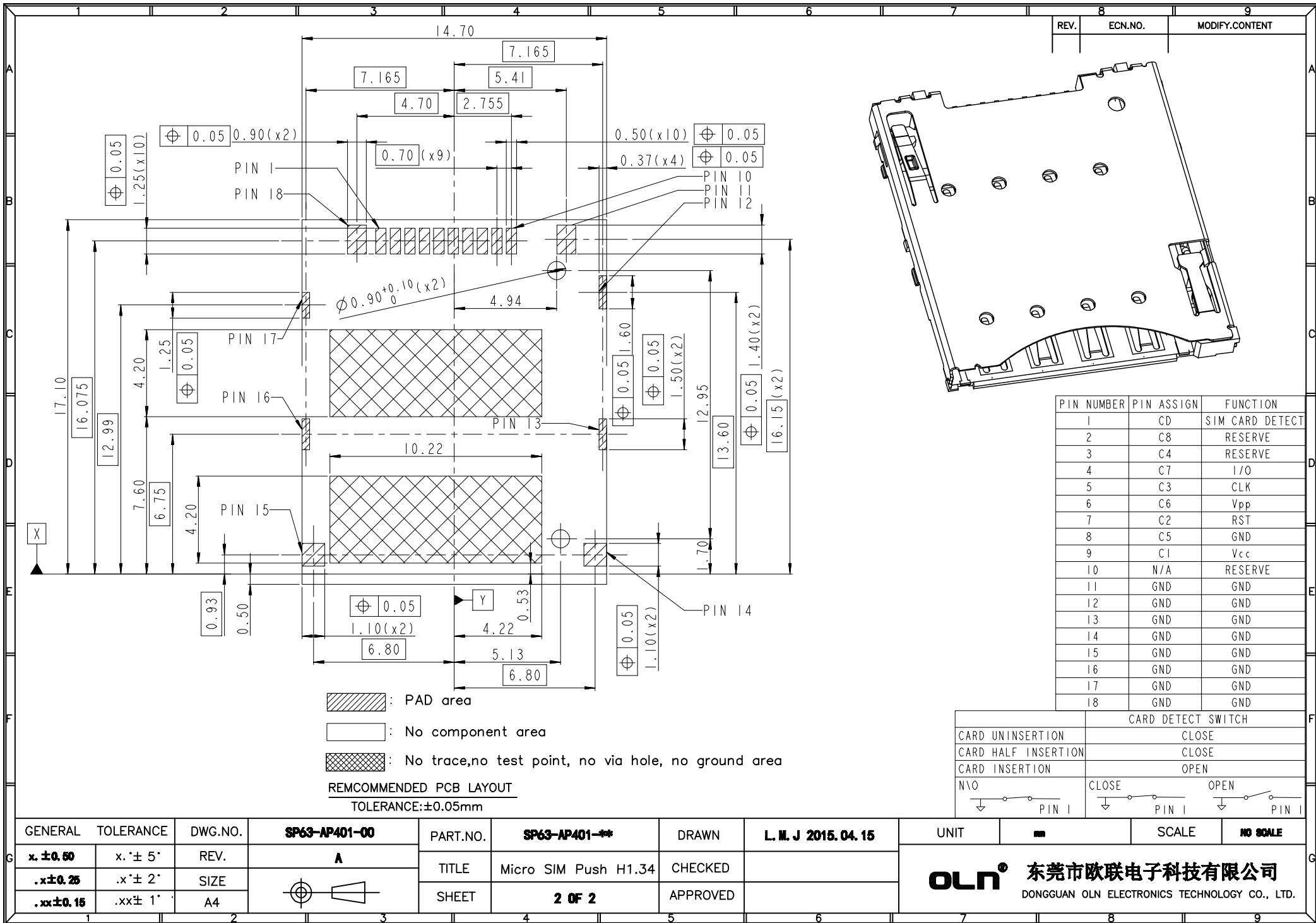

REV.	ECN.NO.	MODIFY.CONTENT

PIN NUMBER	PIN ASSIGN	FUNCTION
1	CD	SIM CARD DETECT
2	C8	RESERVE
3	C4	RESERVE
4	C7	I/O
5	C3	CLK
6	C6	Vpp
7	C2	RST
8	C5	GND
9	C1	Vcc
10	N/A	RESERVE
11	GND	GND
12	GND	GND
13	GND	GND
14	GND	GND
15	GND	GND
16	GND	GND
17	GND	GND
18	GND	GND

CARD DETECT SWITCH	
CARD UNINSERTION	CLOSE
CARD HALF INSERTION	CLOSE
CARD INSERTION	OPEN

N/O	CLOSE	OPEN
PIN 1	PIN 1	PIN 1

: PAD area
 : No component area
 : No trace, no test point, no via hole, no ground area

RECOMMENDED PCB LAYOUT
 TOLERANCE: ±0.05mm

GENERAL TOLERANCE	DWG.NO.	SP63-AP401-00	PART.NO.	SP63-AP401-**-*	DRAWN	L. M. J 2015.04.15
x. ±0.50	REV.	A	TITLE	Micro SIM Push H1.34	CHECKED	
.x ±0.25	SIZE	A4	SHEET	2 OF 2	APPROVED	
.xx ±0.15						

OLN® 东莞市欧联电子科技有限公司
 DONGGUAN OLN ELECTRONICS TECHNOLOGY CO., LTD.

REV.	ECN.NO.	MODIFY.CONTENT

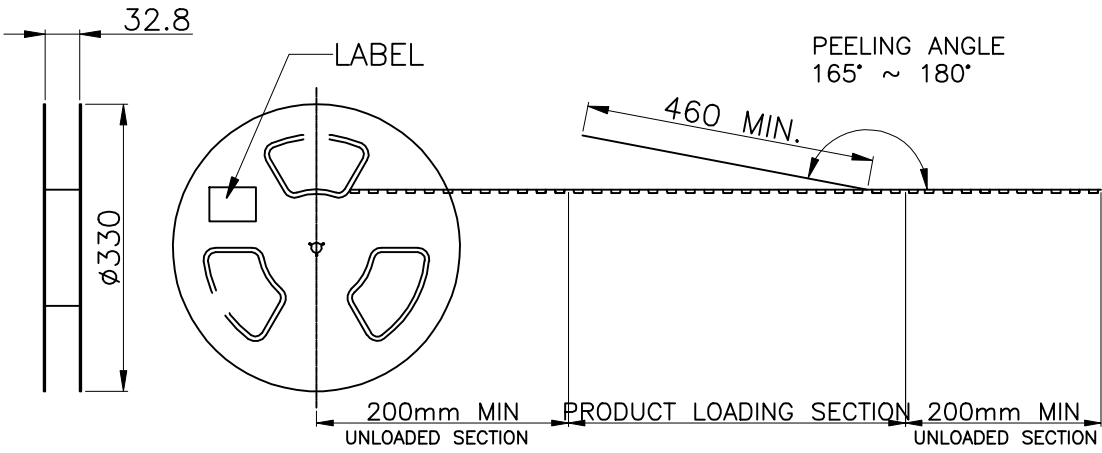

- NOTES :
- MATERIAL :
 COVER TAPE : P.S T=0.05
 CARRIER TAPE : P.S T=0.40
 REEL : PET/PS UL94V-0
 CARTON: CORRUGATED FIBER
 - DIMENSION :
 REEL : SEE DRAWING
 SHIPPING BOX: 350X350X310mm
 - QUANTITY : SEE TABLE
 - PEELING RESISTANCE : 10gf~130gf (for 12~56mm)
 - PEELING SPEED : 300mm/MINUTES

PULL OUT DIRECTION

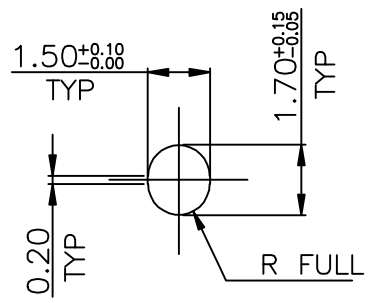
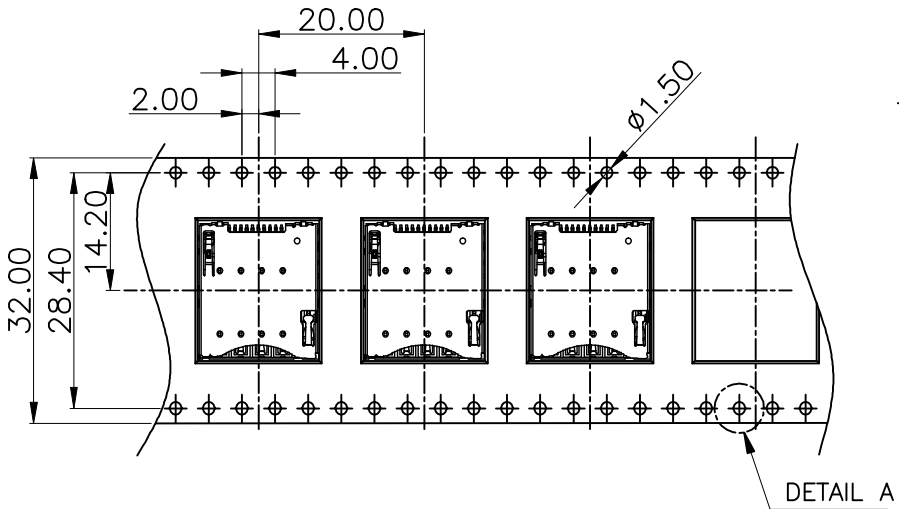

DETAIL A
 SCALE 5:1

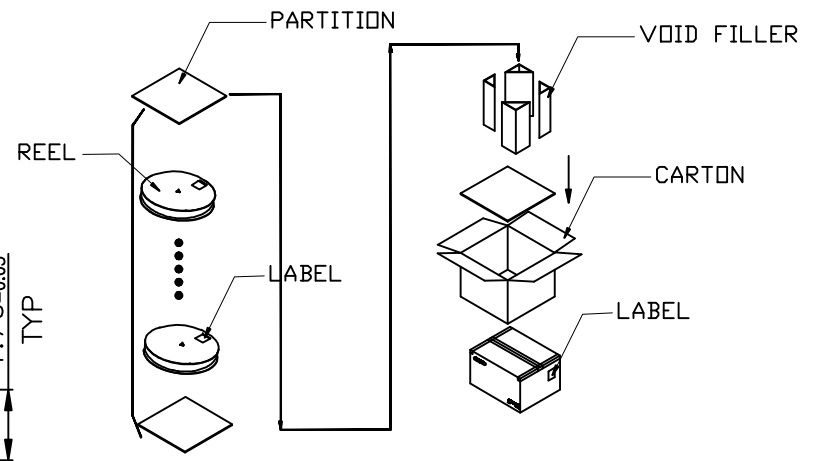

1000	8	8000
PCS/REEL	REEL/BOX	TOTAL Q'TY

GENERAL TOLERANCE	DWG.NO.	SP63-AP401-00	PART.NO.	SP63-AP401-**-*	DRAWN	L. M. J 2015.04.15
x. ±0.50	REV.	A	TITLE	Micro SIM Push H1.34	CHECKED	
.x ±0.25	SIZE		SHEET	1 OF 1	APPROVED	
.xx ±0.15	A4					

OLN® 东莞市欧联电子科技有限公司
 DONGGUAN OLN ELECTRONICS TECHNOLOGY CO., LTD.